



Willamette Falls Heritage Foundation

Spring/Summer Newsletter

May 2016

West Linn Paper welcomes legislative task force

The third meeting of the State Legislative Task Force on April 15 began with a tour of the locks and West Linn Paper Company. (The paper mill is located on an island in the Willamette River that parallels the river's banks and the locks.) The Task Force is studying the state's level of interest in the Locks and will report its findings to the Legislature in 2017. The Locks, which are owned by the United States Army Corps of Engineers, were closed to marine traffic in 2011.

Former Governor Barbara Roberts leads the Task Force in its efforts to compile information about the locks, consider how they could be repaired and reopened, and develop a plan for their sustainable operation and governance in the future.

Legislators appointed to the task force include State Senator Richard Devlin, (who championed the legislation creating the Task Force), Senator Alan Olsen, Representative Julie Parrish and Representative Brent Barton. Other task force members represent Metro, Clackamas County, Oregon City, West Linn, the Port of Portland, State Parks, Transportation, and Marine Board, and business and tribal representatives.



Barbara Roberts (front row, center) and State Task Force (Photo courtesy of Sandy Carter)

Inside

West Linn Paper welcomes legislative task force

Locks working group secures \$500K for studies and repairs

Grindstones art almost finished and almost funded

WFHF 2016 goals

Locks partners pitch in to clean up

President's message

Oregon City Boat Basin, 1867

This could be your last newsletter! (please return response form on page 4)

The National Trust for Historic Preservation, One Willamette River Coalition, and Willamette Falls Heritage Foundation are among organizations working together to reopen the locks. Sandy Carter, of the One Willamette River Coalition and Peggy Sigler, consultant for the National Trust of Historic Preservation, both serve on the Task Force.

The Task Force will build on the work of the One Willamette River Coalition and the Clackamas County Working Group, co-chaired by County Commissioner Tootie Smith and Annette Mattson of Portland General Electric.

Locks Working Group secures \$500K for study and repairs

Clackamas County has received \$500,000 on behalf of the Willamette Falls Locks Working Group to support an economic-potential study and to explore potential interim repairs for the Willamette Falls Locks, which have been closed since 2011.

Governor Kate Brown approved the funds in late March by signing HB 5202 and SB 5701, which were passed by the Oregon Legislature earlier that month.

During its testimony to the legislature, the Working Group recommended funding an economic-potential study to assess the value of repairing and operating the Locks, along with working with the Corps for stopgap repairs needed to reopen the Locks for temporary and minimal usage to demonstrate potential economic viability.

The group promised to seek out a local match of \$100,000 dedicated to the economic-potential study (for a total of \$200,000), leaving \$400,000 in state dollars for the stopgap repairs. Staff supporting the Working Group are collaborating with the Army Corps of Engineers to assess possible uses of the repair funds.

This state funding compliments the Legislature's creation of the Willamette Falls Locks State Task Force in 2015.

Grindstones art almost finished and almost funded

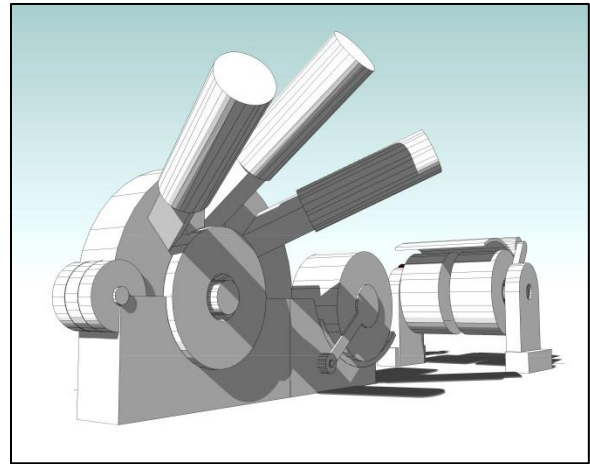

Artist's sketch of paper grinding sculpture (John Davis)

A massive life-size sculpture symbolizing the paper-making process is slated for installation at West Linn's Willamette Park in June.

The sculpture has been a joint project between the City of West Linn and the Willamette Falls Heritage Foundation. Historic grindstones were donated by the West Linn Paper Company to be mounted in the sculpture.

There is still time to donate to the project. Through grants and private donations, the Foundation has raised enough money to pay the artist's contract, however several thousand dollars more are needed for details such as landscaping and interpretive signage.

Two plaques are planned for the sculpture to commemorate donors and mill workers past and present.

Please use the response form in this issue if you are able to help get the Grindstones project over the finish line to its funding goal. Be sure to indicate that you want your donation to be used for the Grindstones project. And thank you!

WFHF 2016 goals

ADMINISTRATION: Continue to enhance board capacity and committee structure; secure new board members with mission-aligned skills and talents; revisit office functions and administrative duties; secure short- and long-term office space; continue to promote the old West Linn City Hall/Police Station as a longer term space option.

FINANCIAL STRENGTHENING: Establish budget and fundraising plans and committees.

PROJECTS AND INITIATIVES; Complete the grindstones project: coordinate signage design, location and installation (includes memorial plaques); continue support of the OWRC and others in efforts to realize restoration of the locks and eventual transfer of ownership from the Corp of Engineers to a regional/state entity; advocate for West Linn Arch Bridge Planning as they relate to historic properties in area; advocate for the beneficial long term health and use of the Corp's museum and its contents; coordinate with PGE and the West Linn Paper Mill on ways and means to preserve Mill A, the groundwood mill; conduct inventory of Foundation "collection" and obtain grant(s) to set up catalog/archival storage system if possible in collaboration with one or more other heritage nonprofits; review and improve newsletter production, website, and social media communications.

Locks partners pitch in to clean up



The "Before" shot – clean and energetic



The "After" shot – tired but still smiling (Photos courtesy of Sandy Carter)

On May 14, the One Willamette River Coalition helped coordinate a work party to remove invasive English ivy and Himalayan blackberries, clean gutters and generally spruce up the park area adjacent to the Willamette Falls locks. Sponsors were USACE, Metro, Clackamas County, the National Trust for Historic Preservation, and the Willamette Falls Heritage Foundation.

This might be your last issue!

Since 2001, the Willamette Falls Heritage Foundation has been a non-profit 501(c)3 organization dedicated to advocating for the preservation and promotion of the special history and heritage we enjoy in the Willamette Falls area. Production of this newsletter is through volunteer efforts and donations from readers like you.

We want to keep you on our mailing list, but we need to hear from you. Please fill out the form on the last page and send it back to us if you would like to keep receiving our newsletters. Note that you can choose to receive an email version instead of a hard copy version if that is your preference. You can also send us an email at willamettefalls@msn.com to let us know you would like to stay on our newsletter list.

Thank you for your interest in the Willamette Falls, the Locks, and the industrial and cultural heritage of this special place at the end of the Oregon Trail.

President's Message

By Troy Bowers

It's a very exciting time at Willamette Falls! Our mission supports a vision at the Falls that reflects upon and honors our rich past while striving for a vital future. The Legacy Project in Oregon City has brought recent and renewed visibility to the Falls and helps build upon the focus and hard work of the WFHF over the past 15 years. Our advocacy for the Civil War era navigational locks is moving conversations and processes forward to Save the Locks and put them back in use for economic benefit to the region. Our economic heritage at the Falls has leveraged the resources at the Falls for our benefit since the time of the Oregon Territory and before. Our paper maker history has been essential for supporting families for generations. The immediately pending installation of a sculpture to honor our paper making history is more than heartfelt to those whose families have built our local communities with their hard work. I thank the many hard working and dedicated WFHF Board members for their vision and persistence over the past 15 years to have us ready to reap the fruits of their labor. I thank the many others who have supported the WFHF vision through your acts and economic support. We have come so far and have much yet to do. Thank you for your continued support!

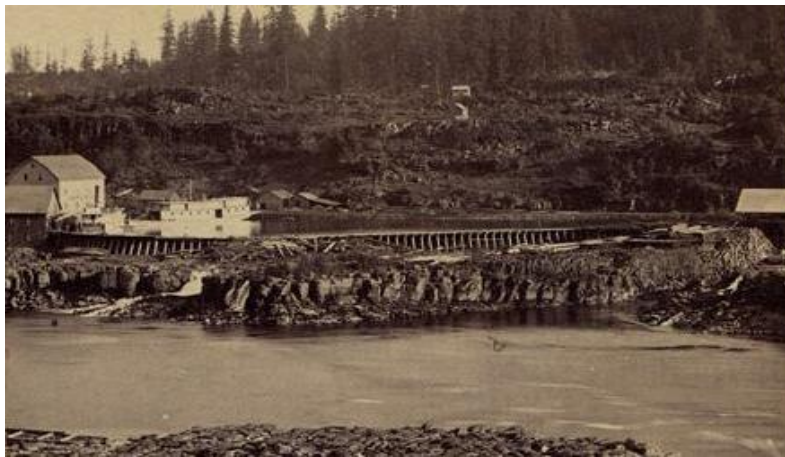

Oregon City boat basin in 1867, looking east from west bank (note sternwheeler in basin) (Courtesy of Wikimedia Commons)

Yes, please continue my Willamette Falls Heritage Foundation newsletter

Name _____

Address _____

City _____ State _____ Zip _____

I prefer to have my newsletter mailed to me

I prefer to receive my newsletter by email Email address _____

I am also enclosing a donation in the amount of _____

(donations may also be made online at www.willamettefalls.org)

Willamette Falls Heritage Foundation is a 501(C)(3) non-profit Oregon corporation established for educational purposes and heritage preservation, and is on the Oregon Cultural Trust's list of qualified Oregon nonprofits.

Willamette Falls Heritage Foundation • PO Box 635 • West Linn, OR 97068

VoiceMail (503) 650-9570 • www.willamettefalls.org

Locks Support at the Falls

Non-Profit

Willamette Falls Heritage Foundation (WFHF)

Charitable non-profit established to promote historic preservation and public awareness of falls - area history.

One Willamette River Coalition (OWRC)

Since 2010, a core coalition of partners (public and private sector) advocating for repair and reopening of the locks.

National Trust for Historic Preservation (NTHP)

National non-profit dedicated to saving historic places, with legal lobbying support for reopening the locks since 2012.

Willamette Falls Legacy Project

Partnership of private owner, Oregon City, Clackamas County, Metro, and State of Oregon to advise on the future of the 23-acre Oregon City paper mill site and build a River Walk with views of the falls.

Willamette Falls Heritage Area Coalition (WFHAC)

Formal coalition of stakeholders working to create Willamette Falls National Heritage Area and manage the WF State Heritage Area.

Government

U.S. Army Corps of Engineers (USACE)

Owens and operates the locks.

Locks Legislative Task Force

Formed by the State Legislature and facilitated by Oregon Solutions, to explore the repair, reopening, and ownership of the locks. Folds in many other partners during its limited term.

Clackamas County Working Group on the Locks

A high-level coalition of public officials, business interests, and the OWRC. Focused on repair and reopening the Locks. Supports state task force.

Metro Regional Government

Supports the regional importance of the Locks, the Legacy Project and proposed National Heritage Area.

Business Partners

Portland General Electric (PGE)

Owens and operates the dam and the historic power plant on the West Linn side of the falls.

West Linn Paper Company

Owens and operates a working paper mill on the West Linn side of the falls.

Native American Tribes

Grand Ronde, Umatilla, Warm Springs, Siletz and Yakama tribes with ties to the falls collaborate with heritage area plans and initiatives and support reopening the Locks.

WILLAMETTE FALLS CANAL & LOCKS

Advocacy Timeline

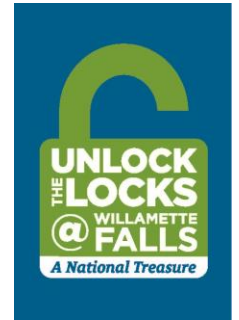

Since 1975, the Willamette locks have been the smallest, oldest operational navigation canal and U.S. locks used for commerce and the smallest and oldest operational U.S. by-pass canal. It has operated nearly continuously for 143 years and still boasts a high degree of integrity, with adaptations that mirror the evolution of technology, function and repairs since construction. We are hopeful that the Willamette Falls Locks will again be open for commercial, recreation and tourism travel. [www.savingplaces.org] [www.willamettefalls.org] Following are highlights and updates from a much deeper list of advocacy efforts on behalf of the West Linn canal and locks.

- ◆ 1974 National Register of Historic Places listing brought the protective mandates of the National Historic Preservation Act (NHPA) for federal properties.
- ◆ 2002 Willamette Falls Heritage Foundation (WFHF) was formed by volunteers to advocate for Willamette Falls Locks and falls-area industrial heritage structures and stories. Six WFHF-sponsored Lock Fests staged between 2004-2014 to raise visibility and advocate for future funding. Congresswoman Darlene Hooley hosted a flotilla to illustrate the importance of one continuous river.
- ◆ 2005 Hooley convened Willamette River United Conference to promote keeping the Locks open, and secured earmarks for summer operations. Gov. Kulongowski designated the Locks as Oregon Solutions (OS) project with Verne Duncan as convener. Willamette River designated as Willamette River Water Trail.
- ◆ 2007 -08 Under OS, \$50K was raised from stakeholders for an INCA engineering study. U.S. Army Corps of Engineers (Corps) closed Locks until Hydraulic Structural Steel (HSS) study could be done.
- ◆ 2009 HSS study began with \$511K Corps funding and \$118K ODOT funds. Local advocacy by WFHF and One Willamette River Coalition (OWRC) garnered \$1.8M in federal stimulus money (ARRA) and \$570K from partners to complete HSS, inspect and repair all gates. OS raised \$29K for a transfer study by Center for Economic Development and Research (CEDER)
- ◆ 2010 Locks' OS project morphed into One Willamette River Coalition.
- ◆ 2011 Canal was transferred to "non-operational" status by the Corps and closed.
- ◆ 2012 Water Trail selected as part of the National Water Trail System. Locks selected as National Treasure by National Trust for Historic Preservation (NTHP) and picked for "Most Endangered" list by Restore Oregon.
- ◆ 2013 Corps allowed two unmanned lockages of the Canby Ferry to move the ferry downstream for retrofitting; OWRC raised \$67k to fund an economic potential report by ECONW citing pent-up recreational demand.
- ◆ 2014 Mandated National Historic Preservation Act (NHPA) Section 106 assessment was begun belatedly by Corps for 2011 closure. Corps acknowledged adverse effects, began mitigation discussions. MOA is in final negotiation phase. NTHP hired Hooley&Natio LLC as Locks champions. Resolutions to repair and reopen the Locks passed unanimously by Clackamas County, Metro, cities of West Linn, Oregon City and Wilsonville.
- ◆ 2015 The Association of Oregon Counties, six cities from Portland to Eugene; five counties along the river, the Confederated Tribes of Grand Ronde, WFHF, Columbia River Yachting Association and industry partners all passed Resolutions to repair and reopen the Locks.
 - JANUARY: Congressman Schrader hosted a VIP tour of the Locks.
 - MARCH: Clackamas County Commissioners convened a Working Group of Locks allies.
 - MAY: \$60,835 contributed by local stakeholders to support continued advocacy efforts for 2015. Supported by WFHF, the Working Group and the Willamette Falls Heritage Area Coalition, SJM Bill 10 passed in the State Legislature, urging Congress to support the Locks and Heritage Area designation.
 - Sen Devlin and co-signers introduced SB131 to create a state Locks Task Force (TF), which Governor Brown signed into law. Staffed by Oregon Solutions and convened by former Governor Barbara Roberts.
 - AUGUST: Senator Wyden hosted a town hall at MOOT, highlighting all three Falls projects.
 - DECEMBER: Members of Oregon's Federal Delegation sent a joint letter to President Obama stating support for repairing and reopening the Locks, and asking for funding for a Disposition Study.
- ◆ 2016 The Governor appointed Sandy Carter to the State Task Force, representing the OWRC. The State Legislature allocated \$500K to the project, with \$100K for a deeper Economic Benefit study and \$400K for repairs.